

Closed Analytical Expressions for Some Useful Sums and Integrals Involving Legendre Functions

G. N. AFANASIEV

*Laboratory of Theoretical Physics, Joint Institute for Nuclear Research,
Dubna, Moscow District, 141 980, U.S.S.R.*

Received May 22, 1985; revised May 15, 1986

Simple closed analytical expressions are obtained for some integrals and infinite sums involving Legendre functions. The results are believed to be new. These sums and integrals may be useful for the calculation of magnetic fields with configurations close to the toroidal ones. The standard results of various asymptotic limits are recovered. © 1987 Academic Press, Inc.

1

In Ref. [1] we have obtained in three different ways the components of the vector magnetic potential (VMP) for the toroidal solenoid. As they satisfy the same equations and the same boundary conditions, they should coincide everywhere (see, e.g., [2]). By comparing these components one can derive simple closed analytical expressions for some integrals and sums involving Legendre functions. These expressions are lacking in the mathematical handbooks, treatises, and original publications [3–12]. Suspecting that in some cases [13] the development of the potential w.r.t. the Legendre functions is invalid, we study the convergence of the treated series in those particular cases. The new expressions found for the sums and integrals may be applied to the calculation of the magnetic field with configurations close to the toroidal ones.

2

As we shall use toroidal coordinates the associated mathematical details are provided. The cylindrical coordinates are expressed in the toroidal system as follows:

$$\rho = a \frac{\text{sh } \mu}{\text{ch } \mu - \cos \theta}, z = a \frac{\sin \theta}{\text{ch } \mu - \cos \theta}, \varphi = \varphi$$
$$(-\pi < \theta < \pi, 0 < \mu < \infty, 0 < \varphi < 2\pi).$$

The torus surface is defined by $\mu = \text{constant}$. The torus $((\rho - d)^2 + z^2 = R^2)$

parameters d and R are expressed as: $R = a/\text{sh } \mu$, $d = a \cdot \text{cth } \mu$. For points on the z axis $\mu = 0$. In the $z = 0$ plane, $\theta = 0$, for $\rho > a$ and $\theta = \pm \pi$ for $\rho < a$.

Let $\mu = \mu_0$ determine a particular solenoid. Then for $\mu > \mu_0$ ($\mu < \mu_0$) the point ρ, z, φ lies inside (outside) the solenoid. The magnetic field equals $H_\varphi = g/\rho$, $H_\rho = H_z = 0$ inside the solenoid and zero outside of it. The constant g depends on the total number of coils and on the current strength: $g = 2nJ/C$; C is the velocity of light.

3

The VMP of the toroidal solenoid may be viewed as a superposition of VMP for separate coils. At the point ρ, z, φ one finds [1],

$$A_z(\rho, z) = \int_0^{2\pi} (d - \rho \cos \varphi) F(\rho, z, \varphi) d\varphi, \tag{3.1}$$

$$A_\rho(\rho, z, \varphi) = z \int_0^{2\pi} \cos \varphi F(\rho, z, \varphi) d\varphi$$

(due to axial symmetry A_ρ and A_z do not depend upon φ and $A_\varphi = 0$). Function F is given by

$$F(\rho, z, \varphi) = \frac{\sqrt{R}}{2\pi} \frac{g}{[(\rho \cos \varphi - d)^2 + z^2]^{3/4}} \cdot Q_{1/2} \left\{ \frac{\rho^2 + z^2 + d^2 + R^2 - 2d\rho \cos \varphi}{2R[(\rho \cos \varphi - d)^2 + z^2]^{1/2}} \right\}.$$

Here and in the following $P_n^v(x)$ and $Q_n^v(x)$ are the Legendre functions of the 1st and 2nd kinds, respectively. If the superscript equals zero, we omit it.

A_z and A_ρ may also be obtained from the solution of the Poisson equation in toroidal coordinates. Thereby, one has [1],

$$A_z = \frac{2\sqrt{2}g}{\pi} \sqrt{\text{ch } \mu - \cos \theta} \sum_{n=0}^{\infty} R_n^0(\mu) \cos n\theta, \tag{3.2}$$

$$A_\rho = \frac{2\sqrt{2}g}{\pi} \sqrt{\text{ch } \mu - \sin \theta} \sum_{n=1}^{\infty} R_n^1(\mu) \cdot \sin n\theta.$$

The functions R_n equal

$$R_n^0(\mu) = C_n(\mu_0) \cdot P_{n-1/2}(\text{ch } \mu_0) \cdot Q_{n-1/2}(\text{ch } \mu),$$

$$R_n^1(\mu) = -Q_{n-1/2}(\text{ch } \mu_0) \cdot [P_{n+1/2}(\text{ch } \mu_0) - P_{n-3/2}(\text{ch } \mu_0)] \cdot Q_{n-1/2}^1(\text{ch } \mu)$$

inside the solenoid ($\mu > \mu_0$) and

$$R_n^0(\mu) = C_n(\mu_0) \cdot Q_{n-1/2}(\text{ch } \mu_0) \cdot P_{n-1/2}(\text{ch } \mu),$$

$$R_n^1(\mu) = -Q_{n-1/2}(\text{ch } \mu_0) \cdot [Q_{n+1/2}(\text{ch } \mu_0) - Q_{n-3/2}(\text{ch } \mu_0)] P_{n-1/2}^1(\text{ch } \mu)$$

outside if $(\mu < \mu_0)$; $C_n(\mu_0) = (1 + \delta_{n0})^{-1} \cdot [(n + \frac{1}{2}) Q_{n+1/2}(\text{ch } \mu_0) - (n - \frac{1}{2}) Q_{n-3/2}(\text{ch } \mu_0)]$.

Equations (3.1) and (3.2) satisfy the same equations and boundary conditions (they are everywhere continuous, finite and tend to zero as r^{-3} for $r \rightarrow \infty$). So they should be the same (details may be found in any textbook on mathematical physics (see, e.g., [2]).

A direct comparison of Eqs. (3.1) and (3.2) is not very useful due to their complexity. Consequently, we consider particular cases. Set $\rho = 0$ in (3.1). Then one has for A_z on the z axis

$$A_z(\rho = 0, z) = \frac{\sqrt{R} g d}{(d^2 + z^2)^{3/4}} \cdot Q_{1/2} \left(\frac{d^2 + z^2 + R^2}{2R \sqrt{d^2 + z^2}} \right). \quad (3.3)$$

Put $\mu = 0$ in (3.2) (this corresponds to the z axis). Taking into the account the behaviour of $P_v^m(\text{ch } \mu)$ for $\mu \rightarrow 0$ [3] and comparing (3.2) and (3.3) one obtains

$$\begin{aligned} & \sqrt{1 - \cos \theta} \sum_{n=0}^{\infty} C_n Q_{n-1/2}(\text{ch } \mu_0) \cos n\theta \\ &= \frac{\pi}{2\sqrt{2}} \frac{\text{ch } \mu_0}{[1 + 2 \text{sh}^2 \mu_0 / (1 - \cos \theta)]^{3/4}} \cdot Q_{1/2} \left[\frac{1 + \text{sh}^2 \mu_0 / (1 - \cos \theta)}{\sqrt{1 + 2 \text{sh}^2 \mu_0 / (1 - \cos \theta)}} \right]. \end{aligned} \quad (3.4)$$

For the particular values of θ one obtains from (3.4) closed expressions for infinite sums involving Legendre functions. Set $\theta = \pi$. Then¹

$$\sum_{n=0}^{\infty} (-1)^n (2n+1) \cdot Q_{n-1/2}(\text{ch } \mu) \cdot Q_{n+1/2}(\text{ch } \mu) = \frac{\pi}{4} \frac{1}{\sqrt{\text{ch } \mu}} Q_{1/2} \left(\frac{1 + \text{ch}^2 \mu}{2 \text{ch } \mu} \right). \quad (3.5)$$

For $\theta \rightarrow 0$ both sides of (3.4) tend to zero as θ^3 , so that equating coefficient at θ^3 one finds

$$\sum_{n=0}^{\infty} (2n+1)^2 \cdot Q_{n-1/2}(\text{ch } \mu) \cdot Q_{n+1/2}(\text{ch } \mu) = \frac{\pi^2 \text{ch } \mu}{8 \text{sh}^3 \mu}. \quad (3.6)$$

Finally, for $\theta = \pi/2$,

$$\begin{aligned} & Q_{-1/2}(\text{ch } \mu) Q_{1/2}(\text{ch } \mu) \\ &+ \sum_{n=1}^{\infty} (-1)^n \cdot Q_{2n-1/2}(\text{ch } \mu) \cdot [(4n+1) \cdot Q_{2n+1/2}(\text{ch } \mu) - (4n-1) Q_{2n-3/2}(\text{ch } \mu)] \\ &= \frac{\pi}{\sqrt{2}} \frac{\text{ch } \mu}{(\text{ch } 2\mu)^{3/4}} Q_{1/2} \left(\frac{1 + \text{ch } 2\mu}{2 \sqrt{\text{ch } 2\mu}} \right). \end{aligned} \quad (3.7)$$

¹ In expression (3.5) and in the following ones ((3.6), (3.7), (3.8)) we omit zero index of μ . So μ in (3.5) has no relation to μ occurring in (3.2). (In fact, we put $\mu = 0$ in (3.2) to obtain (3.4).)

We now prove that Eq.(3.6) converges. For fixed μ and $n \rightarrow \infty$ one has [3], $Q_{n-1/2}(\text{ch } \mu) \approx \sqrt{\pi/2n} \text{sh } \mu \exp(-\mu n)$. So that for $n \rightarrow \infty$,

$$(2n+1)^2 Q_{n-1/2}(\text{ch } \mu) \cdot Q_{n+1/2}(\text{ch } \mu) \approx \frac{\pi}{2 \text{sh } \mu} \frac{(2n+1)^2}{\sqrt{n(n+1)}} \exp[-\mu(2n+1)].$$

It follows that as $n \rightarrow \infty$ the ratio of two successive terms in (3.6) is equal to $\exp(-2\mu)$. Thus, the series (3.6) converges, for any finite $\mu > 0$, as a geometrical progression. Note that one may also derive from (3.4) the following closed expression for the integral:

$$\begin{aligned} & \int_0^{2\pi} \frac{\cos n\theta}{\sqrt{1-\cos \theta}} \frac{d\theta}{[1+2 \text{sh}^2\mu/(1-\cos \theta)]^{3/4}} \cdot Q_{1/2} \left[\frac{1+\text{sh}^2\mu/(1-\cos \theta)}{\sqrt{1+2 \text{sh}^2\mu/(1-\cos \theta)}} \right] \\ &= \frac{2\sqrt{2}}{\text{ch } \mu} Q_{n-1/2}(\text{ch } \mu) \left[\left(n + \frac{1}{2} \right) Q_{n+1/2}(\text{ch } \mu) - \left(n - \frac{1}{2} \right) Q_{n-3/2}(\text{ch } \mu) \right]. \end{aligned} \quad (3.8)$$

Now consider the VMP component A_ρ . For $\rho \rightarrow 0$ it decreases as the first power of μ . Equating coefficients at μ in (3.1) and (3.2) one obtains:

$$\begin{aligned} & \sum_{n=1}^{\infty} (4n^2-1) \cdot Q_{n-1/2}(\text{ch } \mu) \cdot [Q_{n+1/2}(\text{ch } \mu) - Q_{n-3/2}(\text{ch } \mu)] \sin n\theta \\ &= \frac{\pi}{\sqrt{2}} \text{ch } \mu \cdot \text{sh}^2\mu \frac{\sin \theta}{(1-\cos \theta)^{5/2}} \frac{1}{[1+2 \text{sh}^2\mu/(1-\cos \theta)]^{7/4}} \cdot [2Q_{1/2}^1(x) - 3Q_{1/2}(x)], \\ & \quad x = \frac{1+\text{sh}^2\mu/(1-\cos \theta)}{[1+2 \text{sh}^2\mu/(1-\cos \theta)]^{1/2}}. \end{aligned}$$

(Here we again omitted zero index of μ_0 .) As before one assigns to θ specific values. For $\theta \rightarrow 0$ one recovers (3.6), i.e., nothing new. For $\theta \rightarrow \pi$ a new equation is obtained

$$\begin{aligned} & \sum_{n=1}^{\infty} (-1)^n \cdot (n+1) \cdot (2n+1) \cdot Q_{n-1/2}(\text{ch } \mu) \cdot Q_{n+1/2}(\text{ch } \mu) \\ &= -\frac{\pi}{32} \frac{1}{(\text{ch } \mu)^{5/2}} \times [3 \cdot (1+\text{ch}^2\mu) Q_{1/2}(y) + 2 \text{sh}^2\mu \cdot Q_{1/2}^1(y)], \quad y = \frac{1+\text{ch}^2\mu}{2 \text{ch } \mu}. \end{aligned}$$

The convergence of (3.9) is proved along the same lines as that of (3.8). Finally, for $\theta = \pi/2$,

$$\begin{aligned} & \sum_{n=0}^{\infty} (-1)^n \cdot (4n+1) \cdot (4n+3) \cdot Q_{2n+1/2}(\text{ch } \mu) [Q_{2n+3/2}(\text{ch } \mu) - Q_{2n-1/2}(\text{ch } \mu)] \\ &= \frac{\pi}{\sqrt{2}} \text{ch } \mu \cdot \text{sh}^2\mu \frac{1}{(\text{ch } 2\mu)^{7/4}} \cdot [2Q_{1/2}^1(z) - 3Q_{1/2}(z)], \quad z = \frac{\text{ch}^2\mu}{\sqrt{\text{ch } 2\mu}} \end{aligned}$$

4

New relations are obtained if one equates the integral $\oint A_l dl$ along the closed contour passing through the hole of the toroidal solenoid to the magnetic field flow $\phi = \iint \mathbf{H} d\mathbf{S} = 2\pi ga \cdot (\text{cth } \mu_0 - 1)$. For definiteness choose a contour with fixed μ ($< \mu_0$) and φ (see Fig. 1). Then

$$\oint A_l dl = a \int_{-\pi}^{\pi} A_\theta \frac{d\theta}{\text{ch } \mu - \cos \theta}. \quad (4.1)$$

Here A_θ is the tangential component of \mathbf{A} along the treated contour: $A_\theta = -[\text{sh } \mu \cdot \sin \theta A_\rho + (1 - \text{ch } \mu \cdot \cos \theta) A_z](\text{ch } \mu - \cos \theta)^{-1}$. Inserting A_ρ and A_z from (3.2), carrying out the integration in (4.1) and equating the result to ϕ , produces

$$\sum_{n=0}^{\infty} Q_{n-1/2}(\text{ch } \mu) \cdot Q_{n+1/2}(\text{ch } \mu) = \frac{\pi^2}{4} (\text{cth } \mu - 1). \quad (4.2)$$

This relation may also be proved without relying on the physical aspects of the problem. Consider the integral:

$$\int_0^{2\pi} \frac{\cos n\theta}{(\text{ch } \mu - \cos \theta)^A} d\theta, \quad A > 0. \quad (4.3)$$

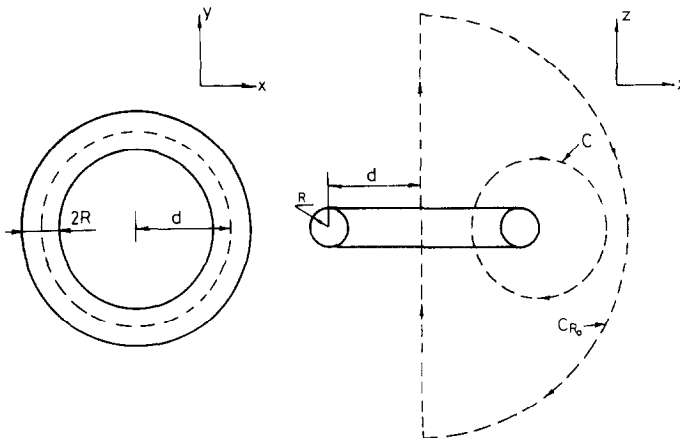

FIG. 1. Schematic presentation of the toroidal solenoid treated. At the right one sees a typical path C (corresponding to $\mu = \text{const.}$, $\varphi = \text{const.}$ along with the integral $\oint A_l dl$ equals the magnetic field flow ϕ . The same is true for the integral along the z axis. In fact one may close this path by the circle C_{R_0} with sufficiently large radius R_0 . For $R_0 \gg d$ the integral along C_{R_0} is negligible, so there remains only the integral along the whole z axis.

Direct integration gives

$$\frac{2\sqrt{2\pi}}{\Gamma(A)} \exp\left[i\pi\left(\frac{1}{2}-A\right)\right] \frac{1}{(\operatorname{sh}\mu)^{A-1/2}} \cdot Q_{n-1/2}^{A-1/2}(\operatorname{ch}\mu). \tag{4.4}$$

The integrand in (4.3) may also be viewed as a product of two cofactors:

$$\frac{\cos n\theta}{(\operatorname{ch}\mu - \cos\theta)^{A_1}} \cdot \frac{1}{(\operatorname{ch}\mu - \cos\theta)^{A-A_1}} \quad (0 < A_1 < A).$$

Expanding both of them in $\cos n\theta$ [3] and integrating as in (4.3) one obtains

$$\begin{aligned} & \frac{4 \exp(-i\pi A)}{\Gamma(A_1) \cdot \Gamma(A-A_1)} \frac{1}{(\operatorname{sh}\mu)^{A-1}} \sum \frac{1}{1+\delta_{m0}} \cdot Q_{m-1/2}^{A-A_1-1/2}(\operatorname{ch}\mu) \\ & \cdot [Q_{m+n-1/2}^{A_1-1/2}(\operatorname{ch}\mu) + Q_{|m-n|-1/2}^{A_1-1/2}(\operatorname{ch}\mu)]. \end{aligned} \tag{4.5}$$

Comparison of (4.4) and (4.5) leads to

$$\begin{aligned} & Q_{n-1/2}^{A_1-1/2}(\operatorname{ch}\mu) \cdot Q_{n-1/2}^{A-A_1-1/2}(\operatorname{ch}\mu) + \sum_{m=1}^{\infty} Q_{m-1/2}^{A-A_1-1/2}(\operatorname{ch}\mu) \\ & \cdot [Q_{m+n-1/2}^{A_1-1/2} + Q_{|m-n|-1/2}^{A_1-1/2}(\operatorname{ch}\mu)] \\ & = \frac{1}{i} \sqrt{\pi/2 \operatorname{sh}\mu} \frac{\Gamma(A_1) \cdot \Gamma(A-A_1)}{\Gamma(A)} \cdot Q_{n-1/2}^{A-1/2}(\operatorname{ch}\mu). \end{aligned} \tag{4.6}$$

Note, the sign of the modulus in $Q_{|m-n|-1/2}^{A_1-1/2}$ may be omitted since, for n integer [3], $Q_{n-1/2}^A(x) = Q_{n-1/2}^A(x)$.

Consider now particular cases of (4.6). For $n=1, A=1, A_1=1/2$ one obtains (4.2) (keep in mind that [3]: $Q_{n-1/2}^{1/2}(\operatorname{ch}\mu) = i\sqrt{\pi/2 \operatorname{sh}\mu} \exp(-\mu n)$). For $n=0, A=1, A_1=1/2$,

$$[Q_{-1/2}(\operatorname{ch}\mu)]^2 + 2 \sum_{n=1}^{\infty} [Q_{n-1/2}(\operatorname{ch}\mu)]^2 = \frac{\pi^2}{2 \operatorname{sh}\mu}. \tag{4.7}$$

The integral

$$\int_{-\infty}^{\infty} A_z(\rho=0, z) dz = \phi^2. \tag{4.8}$$

The equality of (4.8) and ϕ may be independently confirmed by putting $\mu=0$ (this corresponds to the z axis) in Eq. (3.2) for A_z and integrating (4.8) over θ

² This follows from the fact that the integration path along the z axis may be closed by a circle C_{R_0} of sufficiently large radius R_0 (Fig. 1). The integral over C_{R_0} : $R_0 \oint A_{\theta} d\theta_s$ (here θ_s is the polar angle in spherical coordinates and A_{θ} is the component of \mathbf{A} along the C_{R_0}) tends to zero as R_0^{-2} as $R_0 \rightarrow \infty$ (In fact, $A_{\theta} = A_{\rho} \cdot \cos\theta_s - A_z \cdot \sin\theta_s$ and Eq. (3.1) results in the following asymptotic behavior of A_{ρ} and A_z at large distances $A_z \approx \pi g dR^2(1+3\cos 2\theta_s)/8r^3$, $A_{\rho} \approx 3\pi g dR^2 \sin 2\theta_s/8r^3$. S_0 , at $r=R_0$ $A_{\theta} \approx (g dR^2\pi/4R_0^3) \sin\theta_s$.

($dz = -d\theta/(1 - \cos \theta)$). On the other hand one may substitute $A_z(\rho=0, z)$ given by (3.3) into (4.8). Then:

$$\sqrt{R} d \int_0^\infty \frac{dz}{(d^2 + z^2)^{3/4}} \cdot Q_{1/2} \left(\frac{d^2 + z^2 + R^2}{2R \sqrt{d^2 + z^2}} \right) = \pi(d - \sqrt{d^2 - R^2})$$

or in dimensionless variables:

$$\int_0^\infty \frac{dx}{(1+x^2)^{3/4}} Q_{1/2} \left(\frac{1+r^2+x^2}{2r \sqrt{1+x^2}} \right) = \frac{\pi}{\sqrt{2}} (1 - \sqrt{1-r^2}). \quad (4.9)$$

5

The following equations are equivalent to Poisson equations

$$\frac{\partial A_\rho}{\partial z} - \frac{\partial A_z}{\partial \rho} = \frac{g}{\rho} \theta [R - \sqrt{(\rho-d)^2 + z^2}], \quad \text{div } \mathbf{A} = \frac{1}{\rho} \frac{\partial}{\partial \rho} (\rho A_\rho) + \frac{\partial A_z}{\partial z} = 0. \quad (5.1)$$

Here $\theta(x)$ is the step function: $\theta(x) = 1$ if $x > 0$ and 0 if $x < 0$. Now find solutions of (5.1). The gauge condition is automatically satisfied if

$$A_\rho = \frac{1}{\rho} \frac{\partial \psi}{\partial z}, \quad A_z = -\frac{1}{\rho} \frac{\partial \psi}{\partial \rho}. \quad (5.2)$$

Inserting this into the first Eq. (5.1) one obtains a second order equation for ψ . It has the solution

$$\psi = -\frac{4\sqrt{2}g}{\pi} \text{sh } \mu \sqrt{\text{ch } \mu - \cos \theta} \sum_{n=1}^{\infty} \psi_n(\mu) \frac{\sin n\theta}{n^2 - 1/4},$$

where ψ_n is given by

$$\begin{aligned} \psi_n = & Q_{n-1/2}^1(\text{ch } \mu) \cdot \int_{\mu_0}^{\mu} P_{n-1/2}^1(\text{ch } \mu) Q_{n-1/2}^1(\text{ch } \mu) \frac{d\mu}{\text{sh } \mu} \\ & + P_{n-1/2}^1(\text{ch } \mu) \int_{\mu}^{\infty} [Q_{n-1/2}^1(\text{ch } \mu)]^2 \frac{d\mu}{\text{sh } \mu} \end{aligned}$$

inside the solenoid ($\mu > \mu_0$) and $\psi_n = P_{n-1/2}^1(\text{ch } \mu) \int_{\mu_0}^{\infty} [Q_{n-1/2}^1(\text{ch } \mu)]^2 (d\mu/\text{sh } \mu)$ outside it ($\mu < \mu_0$). Substituting ψ and ψ_n in (5.2) and using (3.7) produces the following relations between the integrals occurring in ψ_n ,

$$\begin{aligned} & \int_x^\infty [Q_{n+1/2}^1(x)]^2 \frac{dx}{x^2 - 1} \\ & = \int_x^\infty [Q_{n-1/2}^1(x)]^2 \frac{dx}{x^2 - 1} - \sum_{K=0}^n \left(K + \frac{1}{2} \right) Q_{K+1/2}(x) \cdot Q_{K-1/2}(x), \end{aligned}$$

$$\int_x^\infty P_{n+1/2}^1(x) \cdot Q_{n+1/2}^1(x) \frac{dx}{x^2-1} = \int_x^\infty P_{-1/2}^1(x) Q_{-1/2}^1(x) \frac{dx}{x^2-1} - \sum_{K=0}^n \left(K + \frac{1}{2}\right) Q_{K+1/2}(x) \cdot P_{K-1/2}(x).$$

The derivative w.r.t. x gives

$$2 \sum_{K=0}^n K \cdot [Q_{K-1/2}(x)]^2 = [Q_{-1/2}^1(x)]^2 - \frac{1}{4} [Q_{-1/2}(x)]^2 + \left(n + \frac{1}{2}\right)^2 \cdot [Q_{n+1/2}(x)]^2 - [Q_{n+1/2}^1(x)]^2, \tag{5.3}$$

$$2 \sum_{K=0}^n K \cdot Q_{K-1/2}(x) \cdot P_{K-1/2}(x) = Q_{-1/2}^1(x) \cdot P_{-1/2}^1(x) - \frac{1}{4} P_{-1/2}(x) \cdot Q_{-1/2}(x) + \left(n + \frac{1}{2}\right)^2 \times Q_{n+1/2}(x) \cdot P_{n+1/2}(x) - P_{n+1/2}^1(x) \cdot Q_{n+1/2}^1(x). \tag{5.4}$$

As $n \rightarrow \infty$ Eq. (5.3) goes into

$$2 \sum_{K=1}^\infty K \cdot [Q_{K-1/2}(x)]^2 = [Q_{-1/2}^1(x)]^2 - \frac{1}{4} [Q_{-1/2}(x)]^2, \tag{5.5}$$

whereas both sides of the (5.4) tend to infinity as $n/\text{sh } \mu$.

6

The following analytical equations are based on the fact that outside the solenoid (where $\mathbf{H} = \text{rot } \mathbf{A} = 0$) the VMP may be presented as a gradient of some function χ [14] (which we call a generating function). As $\oint A_i dl$ along the closed contours, passing through a torus hole (Fig. 1) differs from zero, χ is a multivalued (more exactly: discontinuous) function. For the infinitely then toroidal solenoid ($R/d \ll 1$ or $\mu_0 \gg 1$) χ is defined by the relations, following from (3.2),

$$\frac{A_\theta}{\text{ch } \mu - \cos \theta} = \frac{g\pi}{\sqrt{2}} \exp(-2\mu_0) \frac{P_{-1/2}(\text{ch } \mu) \cos \theta - P_{1/2}(\text{ch } \mu)}{\sqrt{\text{ch } \mu - \cos \theta}} = \frac{1}{a} \frac{\partial \chi_0}{\partial \theta},$$

$$\frac{A_\mu}{\text{ch } \mu - \cos \theta} = \sqrt{2} \pi g \exp(-2\mu_0) \frac{\sin \theta}{\sqrt{\text{ch } \mu - \cos \theta}} P_{1/2}^1(\text{ch } \mu) = \frac{1}{a} \frac{\partial \chi_0}{\partial \mu}. \tag{6.1}$$

Now integrate Eqs. (6.1) resp. over θ and μ and equate the results:

$$\begin{aligned}
 & -2\theta + \sum_{n=1}^{\infty} \frac{\sin n\theta}{n} \cdot \{P_{-1/2}(\text{ch } \mu) \cdot [Q_{n+1/2}(\text{ch } \mu) + Q_{n-3/2}(\text{ch } \mu)] \\
 & \quad - 2P_{1/2}(\text{ch } \mu) \cdot Q_{n-1/2}(\text{ch } \mu)\} \\
 & = -2 \left\{ \sum_{n=1}^{\infty} \sin n\theta \cdot \int_0^{\mu} P_{-1/2}^1(\text{ch } \mu) [Q_{n+1/2}(\text{ch } \mu) - Q_{n-3/2}(\text{ch } \mu)] d\mu \right. \\
 & \quad \left. + \pi \left(1 - \cos \frac{\theta}{2}\right) \text{sgn } \theta \right\}. \tag{6.2}
 \end{aligned}$$

Taking into account [6], that

$$\sum_{n=1}^{\infty} \frac{1}{n} \frac{\sin n\theta}{n^2 - 1/4} = 2\theta - 2\pi \left(1 - \cos \frac{\theta}{2}\right) \text{sgn } \theta$$

and comparing coefficients at $\sin n\theta$ in (6.2) one obtains

$$\begin{aligned}
 & \int_1^x P_{-1/2}^1(x) \cdot Q_{n-1/2}^1(x) dx \\
 & = \frac{1}{4} \left(\frac{1}{4n^2} - 1 \right) \{P_{-1/2}(x) \cdot [Q_{n+1/2}(x) + Q_{n-3/2}(x)] \\
 & \quad - 2 \cdot P_{1/2}(x) \cdot Q_{n-1/2}(x)\} + \frac{1}{4n^2}, \quad n \geq 1. \tag{6.3}
 \end{aligned}$$

When $\mu \rightarrow \infty$, (6.3) goes into

$$\int_1^x P_{1/2}(x) \cdot Q_{n-1/2}^1(x) dx = \frac{1}{4n^2}. \tag{6.4}$$

Applying the same procedure to a solenoid of finite thickness ($R \sim d$) one gets [1] a system of finite difference equations for the integrals $F_n = \int_1^x [Q_{n-1/2}(x)]^2 dx$ and $C_n = \int_1^x P_{n-1/2}(x) \cdot Q_{n-1/2}(x) dx$. This system may be solved and one obtains the following simple analytic equations for F_n and C_n ,

$$\begin{aligned}
 n \cdot F_n & = \sqrt{x^2 - 1} \sum_{K=0}^{n-1} \frac{1}{2K+1} [Q_{K+1/2}(x) \cdot Q_{K+1/2}^1(x) - Q_{K-1/2}(x) \cdot Q_{K-1/2}^1(x)] \\
 & \quad - \frac{1}{2} \sum_{K=0}^{n-1} \frac{1}{(K+1/2)^2}, \tag{6.5}
 \end{aligned}$$

$$n \cdot C_n = \sqrt{x^2 - 1} \sum_{K=0}^{n-1} \frac{1}{2K+1} [Q_{K+1/2}(x) \cdot P_{K+1/2}^1(x) - Q_{K-1/2}(x) \cdot P_{K-1/2}^1(x)].$$

As $x \rightarrow \infty$, the first of the relations goes into the known one [3],

$$2n \int_1^x [Q_{n-1/2}(x)]^2 dx = \frac{\pi^2}{2} - \sum_{K=0}^{n-1} \frac{1}{(K+1/2)^2},$$

whereas both sides of the second relation (6.5) behave like $\ln \sqrt{x}$. As $\mu_0 \rightarrow \infty$ the generating function for the toroidal solenoid of finite thickness ($R \sim d$) should pass into χ_0 (given by (6.2.)). This leads to the following condition [1]

$$-\frac{1}{4} S_n = 2n [P_{n-1/2}(x) \cdot F_n - Q_{n-1/2}(x) \cdot C_n] + \left[\sum_{K=0}^{n-1} \frac{1}{(K+1/2)^2} - \frac{\pi^2}{2} \right] \cdot P_{n-1/2}(x), \tag{6.6}$$

where S_n is given by

$$S_n = \sum_{K=1}^{\infty} \{ [Q_{K+1/2}(x) + Q_{K-3/2}(x)] P_{-1/2}(x) - 2Q_{K-1/2}(x) \cdot P_{1,2}(x) \} \\ \times [Q_{K-n-1/2}(x) - Q_{K+n-1/2}(x)] / K.$$

Equation (6.6) generates many useful relations. For example, as $x \rightarrow \infty$ one obtains

$$\sum_{K=1}^n \frac{\Gamma(K-1/2) \cdot \Gamma(n-K+1/2)}{\Gamma(K+1) \cdot \Gamma(n-K+1)} = 2 \sqrt{\pi} \frac{\Gamma(n+1/2)}{\Gamma(h)}. \tag{6.7}$$

Although similar to the Dougoll formula [3], it does not reduce to it.

7

Here we collect together some sums and integrals:

$$\sum_{n=0}^{\infty} (-1)^n \cdot (2n+1) \cdot Q_{n-1/2}(x) \cdot Q_{n+1/2}(x) = \frac{\pi}{4} \frac{1}{\sqrt{x}} Q_{1/2} \left(\frac{1+x^2}{2x} \right), \tag{7.1}$$

$$\sum_{n=0}^{\infty} (2n+1)^2 \cdot Q_{n-1/2}(x) \cdot Q_{n+1/2}(x) = \frac{\pi^2}{8} \frac{x}{(x^2-1)^{3/2}}, \tag{7.2}$$

$$Q_{-1/2}(x) \cdot Q_{1/2}(x) + \sum_{n=1}^{\infty} (-1)^n \cdot Q_{2n-1/2}(x) \\ \cdot [(4n+1) Q_{2n+1/2}(x) - (4n-1) \cdot Q_{2n-3/2}(x)] \\ = \frac{\pi}{\sqrt{2}} \frac{x}{(2x^2-1)^{3/4}} Q_{1/2} \left(\frac{x^2}{\sqrt{2x^2-1}} \right), \tag{7.3}$$

$$\begin{aligned} & \sum_{n=1}^{\infty} (-1)^n n \cdot (n+1) \cdot (2n+1) \cdot Q_{n-1/2}(x) \cdot Q_{n+1/2}(x) \\ &= -\frac{\pi}{32} \frac{1}{x^{5/2}} \cdot \left[3 \cdot (1+x^2) \cdot Q_{1/2} \left(\frac{1+x^2}{2x} \right) + 2(x^2-1) \cdot Q_{1/2}^1 \left(\frac{1+x^2}{2x} \right) \right], \end{aligned} \quad (7.4)$$

$$\begin{aligned} & \sum_{n=0}^{\infty} (-1)^n \cdot (4n+1) \cdot (4n+3) \cdot Q_{2n+1/2}(x) \cdot [Q_{2n+3/2}(x) - Q_{2n-1/2}(x)] \\ &= \frac{\pi}{\sqrt{2}} \frac{x \cdot (x^2-1)}{(2x^2-1)^{7/4}} \cdot \left[2 \cdot Q_{1/2}^1 \left(\frac{x^2}{\sqrt{2x^2-1}} \right) - 3Q_{1/2} \left(\frac{x^2}{\sqrt{2x^2-1}} \right) \right], \end{aligned} \quad (7.5)$$

$$\sum_{n=0}^{\infty} Q_{n-1/2}(x) \cdot Q_{n+1/2}(x) = \frac{\pi^2}{4} \left(\frac{x}{\sqrt{x^2-1}} - 1 \right), \quad (7.6)$$

$$[Q_{-1/2}(x)]^2 + 2 \sum_{n=1}^{\infty} [Q_{n-1/2}(x)]^2 = \frac{\pi^2}{2\sqrt{x^2-1}}, \quad (7.7)$$

$$\int_0^x \frac{dx}{(1+x^2)^{3/4}} Q_{1/2} \left(\frac{1+r^2+x^2}{2r\sqrt{1+x^2}} \right) = \frac{\pi}{\sqrt{r}} (1 - \sqrt{1-r^2}) \quad (0 \leq r \leq 1), \quad (7.8)$$

$$\begin{aligned} & 2 \sum_{k=0}^n K [Q_{k-1/2}(x)]^2 \\ &= [Q_{-1/2}^1(x)]^2 - \frac{1}{4} [Q_{-1/2}(x)]^2 + \left(n + \frac{1}{2} \right)^2 [Q_{n+1/2}(x)]^2 - [Q_{n+1/2}^1(x)]^2 \end{aligned} \quad (7.9)$$

$$\begin{aligned} & 2 \sum_{k=0}^n K \cdot Q_{k-1/2}(x) \cdot P_{k-1/2}(x) \\ &= Q_{-1/2}^1(x) \cdot P_{-1/2}^1(x) - \frac{1}{4} Q_{-1/2}(x) \cdot P_{-1/2}(x) + \left(n + \frac{1}{2} \right)^2 \\ & \quad \times Q_{n+1/2}(x) \cdot P_{n+1/2}(x) - P_{n+1/2}^1(x) \cdot Q_{n+1/2}^1(x), \end{aligned} \quad (7.10)$$

$$2 \sum_{k=0}^{\infty} K \cdot [Q_{k-1/2}(x)]^2 = [Q_{-1/2}^1(x)]^2 - \frac{1}{4} [Q_{-1/2}(x)]^2, \quad (7.11)$$

$$\begin{aligned} & \int_1^x P_{-1/2}^1(x) \cdot Q_{n-1/2}^1(x) dx \\ &= \frac{1}{4} \left(\frac{1}{4n^2} - 1 \right) \{ P_{-1/2}(x) \cdot [Q_{n+1/2}(x) + Q_{n-3/2}(x)] \\ & \quad - 2 \cdot P_{1/2}(x) \cdot Q_{n-1/2}(x) \} + \frac{1}{4n^2}, \end{aligned} \quad (7.12)$$

$$\int_1^x P_{-1/2}^1(x) \cdot Q_{n-1/2}^1(x) dx = \frac{1}{4n^2}, \tag{7.13}$$

$$\begin{aligned} n \int_1^x [Q_{n-1/2}(x)]^2 dx &= \sqrt{x^2-1} \sum_{K=0}^{n-1} \frac{1}{2K+1} \cdot [Q_{K+1/2}(x) Q_{K+1/2}^1(x) \\ &\quad - Q_{K-1/2}(x) Q_{K-1/2}^1(x)] - \frac{1}{2} \sum_{K=0}^{n-1} \left(K + \frac{1}{2}\right)^2, \end{aligned} \tag{7.14}$$

$$\begin{aligned} n \int_1^x Q_{n-1/2}(x) \cdot P_{n-1/2}(x) dx &= \sqrt{x^2-1} \sum_{K=0}^{n-1} \frac{1}{2K+1} \\ &\quad \cdot [Q_{K+1/2}(x) \cdot P_{K+1/2}^1(x) - Q_{K-1/2}(x) \cdot P_{K-1/2}^1(x)], \end{aligned} \tag{7.15}$$

$$\sum_{K=1}^n \frac{\Gamma(K-1/2) \Gamma(n-K+1/2)}{\Gamma(K+1) \Gamma(n-K+1)} = 2\sqrt{\pi} \frac{\Gamma(n+1/2)}{\Gamma(n+1)}. \tag{7.16}$$

In all these relations x is always greater than 1; $n \geq 0$ in (7.9) and (7.10) and $n \geq 1$ in (7.12)–(7.16).

Many useful relations may be obtained by applying the Whipple relation [3] between the Legendre functions to (7.1)–(7.15) (from e.g., (7.2) and (7.6)),

$$\sum_{n=0}^{\infty} \frac{2n+1}{[\Gamma(n+1/2)]^2} \cdot P_{n-1/2}^n(x) \cdot P_{n+1/2}^{n+1}(x) = -\frac{1}{8\pi} x \sqrt{x^2-1}, \tag{7.2'}$$

$$\sum_{n=0}^{\infty} \frac{1}{\Gamma(n+1/2) \cdot \Gamma(n+3/2)} P_{n-1/2}^n(x) P_{n+1/2}^{n+1}(x) = -\frac{1}{2\pi} \sqrt{(x-1)/(x+1)}. \tag{7.6'}$$

REFERENCES

1. G. N. AFANASIEV, JINR, E2-83-339, Dubna, 1983; E-4-84-65, Dubna, 1984.
2. R. COURANT AND D. HILBERT, *Methods of Mathematical Physics*, Vol. II, (Interscience, New York, 1962), p. 254.
3. H. BATEMAN AND A. ERDELYI, *Higher Transcendental Functions*, Vol. I, (McGraw-Hill, New York/Toronto/London, 1953).
4. E. W. HOBSON, *Theory of Spherical and Ellipsoidal Harmonics* (Cambridge Univ. Press, London, 1931).
5. L. ROBIN, *Fonctions spherique de Legendre et fonctions spheroidales* Vol. 1-3 (Gauthier-Villars, Paris, 1957-1959).
6. I. S. GRADSCHEYAN AND I. M. RYZIK, *Tables of Integrals, Series and Products* (Academic Press, New York, 1965).
7. A. D. WHEELON, *Tables of Summable Series and Integrals involving Bessel functions* (Holden-Day, San Francisco, 1968).

8. A. P. PRUDNIKOV, YU. A. BRYCHKOV, AND O. I. MARICHEV, *Integral and Series*, Vol. 1, 2 (Nauka, Moscow, 1981–1983).
9. W. MAGNUS, F. OBERHETTINGER AND R. P. SONI, *Formulas and Theorems for the Special functions of Mathematical Physics* (Springer, Berlin, 1966).
10. E. R. HANSEN, *A Table of Series and Products* (Prentice–Hall, New York, 1975).
11. M. ABRAMOWITZ AND I. A. STEGUN, *Handbook of Mathematical Functions* (Dover, New York, 1965).
12. H. VAN HAERINGEN AND L. P. KUK, *J. Math. Phys.* **22**, 2482 (1981); H. VAN HAERINGEN, *J. Math. Phys.* **23**, 1964 (1982); **24**, 1054. (1983); A. GERVOIS AND H. NAVELET, *J. Math. Phys.* **26**, 639 (1985); A. BEIG, *J. Math. Phys.* **26**, 769 (1985).
13. P. R. BRAZIER-SMITH, *J. Comput. Phys.* **54**, 524 (1984).
14. S. N. M. RUIJSENAARS, *Ann. Phys. (N.Y.)* **146**, 1 (1983); H. J. ROTHE, *Nuovo Cimento A* **62**, 54 (1981); D. BOHM, R. D. KAYE, AND C. PHILLIPIDIS, *Nuovo Cimento B* **71**, 75 (1982).